

INSTALLED INSTRUCTION AR-1500WS ELECTROMAGNETIC LOCK



► SPECIFICATION

DESCRIPTION	AR-1500WS
Door monitoring output (reel sensor NO/NC)	⊙
Input Voltage	12 to 24 VDC
Current Draw	12VDC - 500mA 24VDC - 250mA
Holding Force	1300LBS
Dimensions(L x W x D)	
Surface magnet	225 x 65 x 42 mm
Strike plate	185 x 61 x 16 mm
Material	
Armature housing	Stainless steel
Strike plate	Steel

► OUT SWING DOOR ASSEMBLY

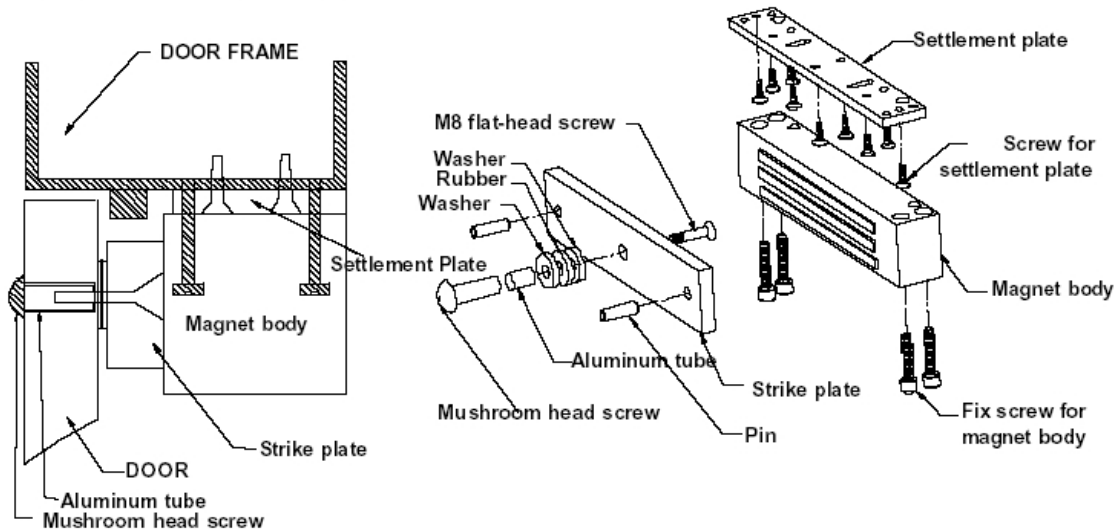

1. First, loosely attach the settlement plate to the doorframe by inserting 2 screws through the 2 pre-drilled holes of the settlement plate. Adjust the settlement plate to the desired position, then tighten the settlement plate to the doorframe with another 10 screws.
2. Insert 2 included screws through the pre-drilled holes on the lock body and screw tightly with the settlement plate.
3. Locate the proper position on the door that corresponds to the position of the electromagnetic lock when closed. Insert 2 pins to the strike plate and drill 2 holes (about 6~7mm) on the door at the center of the strike plate all the way through the entire door. Insert the M8 flat head screw through the center of the strike plate, through the door, the washers, the aluminum tube and bolt. Do not install the strike plate too tight. Leave some space to allow for best performance between the plate and lock.

► ELECTRICAL INSTALLATION

